

DESCRIBE DAMAGE Vehicle 1 Check box(es) representing vehicle damage area.

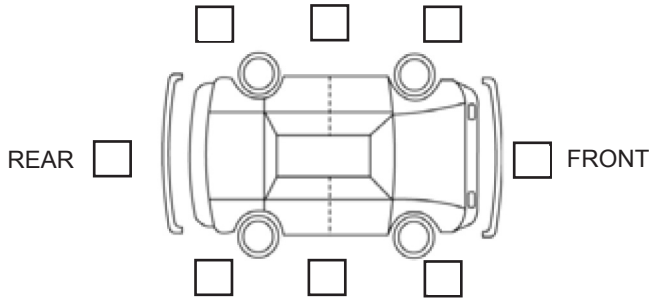

DESCRIBE DAMAGE Vehicle 2 Check box(es) representing vehicle damage area.

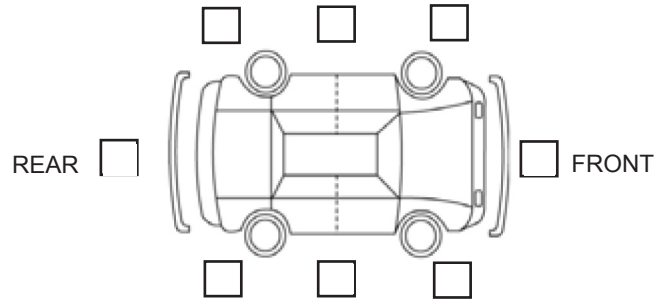

WAS MEDICAL ASSISTANCE CALLED TO THE SCENE Y N

IDENTIFY PERSON(S) REQUIRING MEDICAL ASSISTANCE

WERE THERE ANY WITNESSES TO THE INCIDENT Y N

PLEASE LIST WITNESSES NAME AND CONTACT INFORMATION

TYPE OF INCIDENT/ACCIDENT

- | | |
|--|--------------------------------------|
| COLLISION WITH: | NON COLLISION WITH: |
| <input type="checkbox"/> OTHER MOTOR VEHICLE | <input type="checkbox"/> OVERTURN |
| <input type="checkbox"/> MOTOR VEHI. CROSSING MEDIAN | <input type="checkbox"/> SPILL |
| <input type="checkbox"/> PARKED MOTOR VEHICLE | <input type="checkbox"/> FIRE |
| <input type="checkbox"/> BICYCLIST | <input type="checkbox"/> SUBMERSION |
| <input type="checkbox"/> PEDESTRIAN | <input type="checkbox"/> JACKKNIFE |
| <input type="checkbox"/> ANIMAL | <input type="checkbox"/> EXPLOSION |
| <input type="checkbox"/> THROWN OR FALLING OBJECT | <input type="checkbox"/> OTHER _____ |
| <input type="checkbox"/> MOTORCYCLE | |
| <input type="checkbox"/> FIXED OBJECT | |

IF ACCIDENT INVOLVED FIXED OBJECT (above)
CHECK THE OBJECT STRUCK:

- | | |
|---|--|
| <input type="checkbox"/> TRAFFIC SIGNAL | <input type="checkbox"/> BARRIER/FENCE |
| <input type="checkbox"/> SIGN POST | <input type="checkbox"/> EMBANKMENT |
| <input type="checkbox"/> GUARD RAIL | <input type="checkbox"/> FIRE HYDRANT |
| <input type="checkbox"/> CRASH CUSHION | <input type="checkbox"/> DITCH/CURB |
| <input type="checkbox"/> LIGHT POLE | <input type="checkbox"/> PARKING METER |
| <input type="checkbox"/> TELEPHONE POLE | <input type="checkbox"/> OTHER _____ |
| <input type="checkbox"/> TREE | |
| <input type="checkbox"/> BUILDING/WALL | |
| <input type="checkbox"/> BRIDGE/PIER | |
| <input type="checkbox"/> MEDIAN | |

ACCIDENT LOCATION

- | | |
|---|---|
| <input type="checkbox"/> INTERSECTION | <input type="checkbox"/> RAMP/ROTARY |
| <input type="checkbox"/> LOCAL STREET | <input type="checkbox"/> IN DRIVEWAY |
| <input type="checkbox"/> ALONG THE ROAD | <input type="checkbox"/> IN PARKING LOT |
| <input type="checkbox"/> ALONG ROAD @ DRIVEWAY | <input type="checkbox"/> ON HIGHWAY |
| <input type="checkbox"/> OFF ROAD ON SHOULDER | <input type="checkbox"/> OTHER _____ |
| <input type="checkbox"/> OFF ROAD BEYOND SHOULDER | |

TRAFFIC CONTROLS

- | | |
|--|---|
| <input type="checkbox"/> NONE | <input type="checkbox"/> VISIBLE ROAD MARKINGS |
| <input type="checkbox"/> TRAFFIC SIGNALS | <input type="checkbox"/> OFFICER/FLAGMAN |
| <input type="checkbox"/> STOP SIGN | <input type="checkbox"/> RR CROSSING FLASHER GATE |
| <input type="checkbox"/> YIELD SIGN | <input type="checkbox"/> NO PASSING ZONE |
| <input type="checkbox"/> LANE CONTROL | <input type="checkbox"/> OTHER _____ |

ROAD DESIGN

- | | |
|---|--------------------------------------|
| <input type="checkbox"/> INTERSTATE | <input type="checkbox"/> ONE WAY |
| <input type="checkbox"/> OTHER DIVIDED HWGHY | <input type="checkbox"/> DRIVEWAY |
| <input type="checkbox"/> ROAD NOT DIVIDED (2-WAY) | <input type="checkbox"/> ACCESS WAY |
| | <input type="checkbox"/> OTHER _____ |

ROAD CONDITIONS

- | | |
|-------------------------------------|---|
| <input type="checkbox"/> DRY | <input type="checkbox"/> DEBRIS |
| <input type="checkbox"/> WET | <input type="checkbox"/> SAND/DUST/OIL |
| <input type="checkbox"/> SNOW/SLUSH | <input type="checkbox"/> POT HOLE |
| <input type="checkbox"/> ICE | <input type="checkbox"/> UNDER CONSTRUCTION |
| <input type="checkbox"/> MUDDY | <input type="checkbox"/> OTHER _____ |

WEATHER CONDITION

- | |
|--------------------------------------|
| <input type="checkbox"/> CLEAR |
| <input type="checkbox"/> FOGGY |
| <input type="checkbox"/> CLOUDY |
| <input type="checkbox"/> RAINING |
| <input type="checkbox"/> SLEETING |
| <input type="checkbox"/> SNOWING |
| <input type="checkbox"/> OTHER _____ |

LIGHT CONDITION

- | |
|---|
| <input type="checkbox"/> DAYLIGHT |
| <input type="checkbox"/> SUNGLARE |
| <input type="checkbox"/> DAWN/DUSK |
| <input type="checkbox"/> NIGHT - ROAD LIT |
| <input type="checkbox"/> NIGHT - ROAD NOT LIT |

DESCRIBE INCIDENT: